



Product Parameters (产品描述)

产品编号 | Part Number: KB-H18-xxF-3030
出光角度 | Beam Angle: 20/45/20*45°
产品材料 | Material: PMMA
工作温度 | Work Temp: <85°C

安装方式 | Fastening: Glue+Pins
支架颜色 | Holder Color: N/A
透光率 | Transmittance: 93%
匹配LED | Match Led: Flat 3030 & Dome 3535

Part Number	Lens Surface	Dimension	Beam Angle
KB-H18-20PF-3030	珠面/beads	Φ18.5*H10.82mm	~20°
KB-H18-45PF-3030	珠面/beads	Φ18.5*H10.82mm	~45°
KB-H18-2045F-3030	条纹/strip	Φ18.5*H10.82mm	~20*45°

Direction for Use

(透镜 | LENS)

- 1, Please use some soft paper or pure water to clean lens (reflector)
- 2, Don't use any industrial solvent to clean lens surface , such as alcohol
- 3, Storage environment : Temperature 0~40°C , Humidity 30%~95%
- 4, This kind of lens can make the lighting more concentrated, and it's made from transparent material , so please do not open the packages until you use them, in case of the dust and other pollutions.

Light Distribution Curve (配光曲线图):

Part Number: KB-H18-20PF-3030 +3030 Led tested

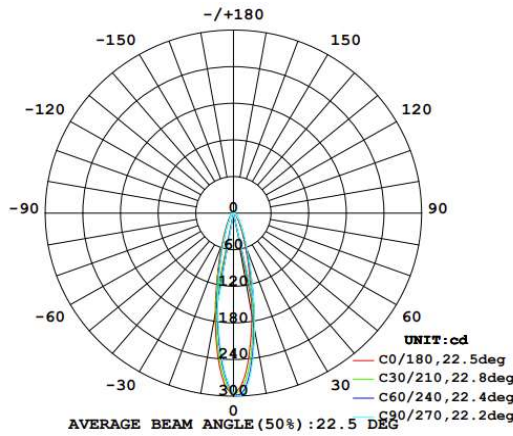

Part Number: KB-H18-45PF-3030 +3030 Led tested

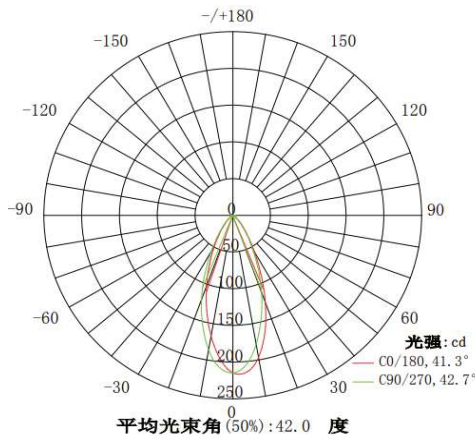

Part Number: KB-H18-2045F-5050 +XPE2 led test

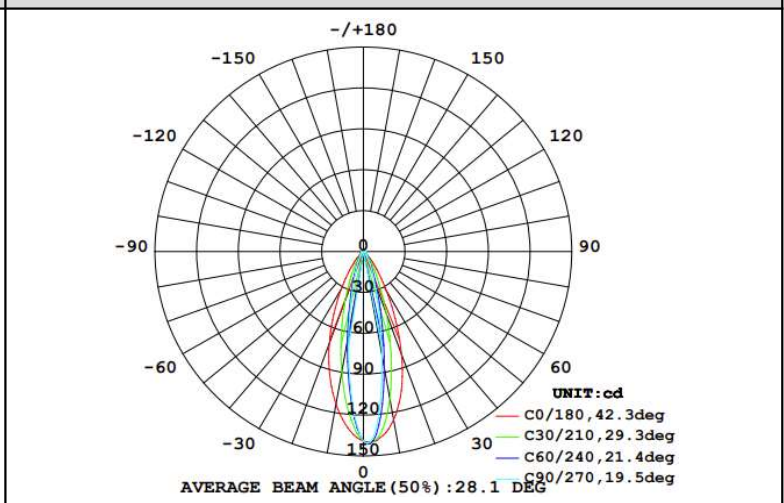
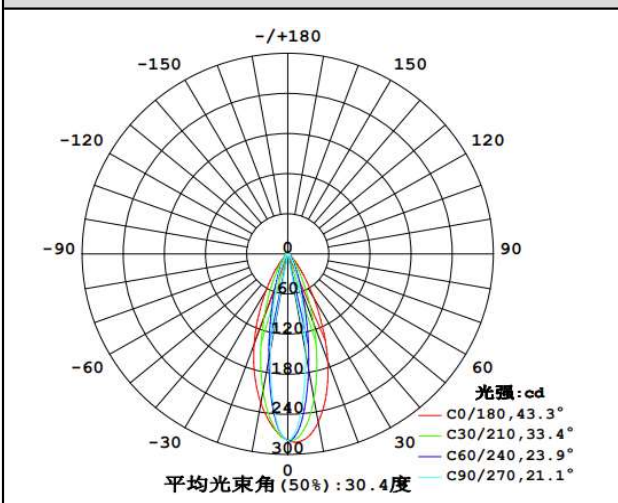

Part Number: KB-H18-2045F-3030 +3030 led tested

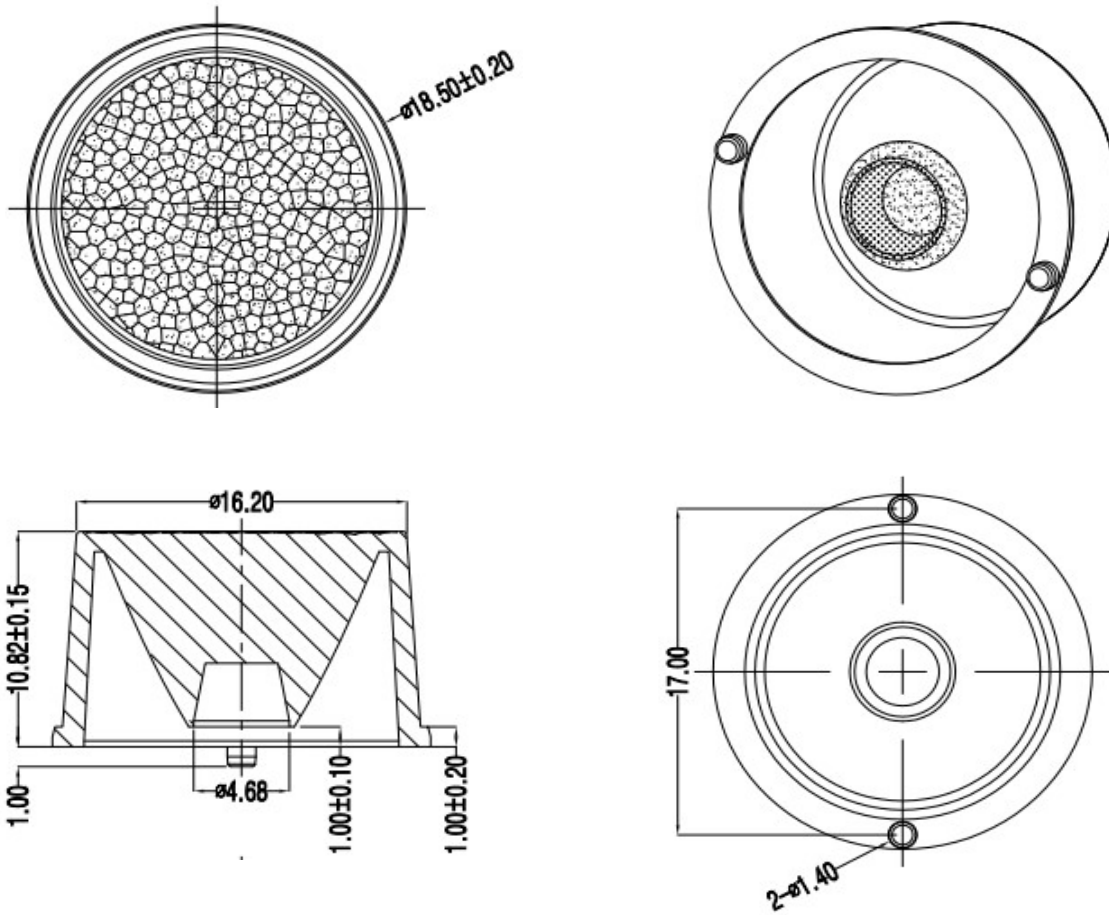

Mechanical Characteristics (产品尺寸):



Product Package (产品包装):

Inner Box (内盒)	Outer Carton (外箱)
	
<p>500pcs/bag 1 bag/box Gross weight: 645g/box Box dimension: 12.2*12.3*13.4cm</p>	<p>20boxes/carton 10,000pcs/carton Gross weight: 14.0kg/CTN Carton Dimension: 64*29*26cm</p>