



**Product Parameters (产品描述)**

产品编号 | Part Number: KB-H20-xx-RGBW  
 出光角度 | Beam Angle: 25/45/60/90/120°  
 产品材料 | Material: Lens-PMMA/Holder-PC  
 工作温度 | Work Temp: <85°C

安装方式 | Fastening: Glue  
 支架颜色 | Holder Color: White/Black  
 透光率 | Transmittance: 93%  
 匹配LED | Match Led: Epistar RGB Led



Part Number	Lens Surface	Dimension	Beam Angle
KB-H20-25P-RGBW	珠面/beads	Φ21.5*H14mm	~25°
KB-H20-45P-RGBW	珠面/beads	Φ21.5*H14mm	~45°
KB-H20-60P-RGBW	珠面/beads	Φ21.5*H14mm	~60°
KB-H20-90P-RGBW	珠面/beads	Φ21.0*H14mm	~90°
KB-H20-120P-RGBW	珠面/beads	Φ21.0*H14mm	~120°

**Direction for Use**



**(透镜 | LENS)**

- 1, Please use some soft paper or pure water to clean lens ( reflector)
- 2, Don't use any industrial solvent to clean lens surface , such as alcohol
- 3, Storage environment : Temperature 0~40°C , Humidity 30%~95%
- 4, This kind of lens can make the lighting more concentrated, and it's made from transparent material , so please do not open the packages until you use them, in case of the dust and other pollutions.

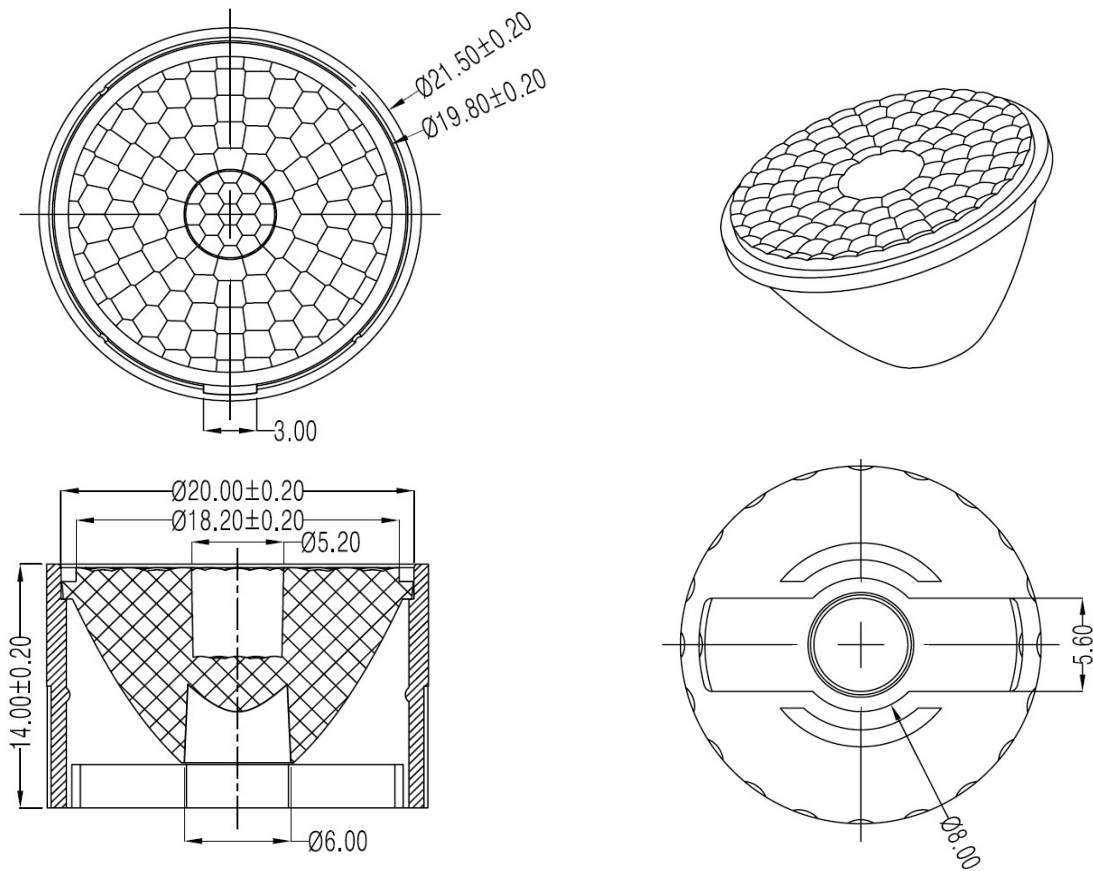
**Mechanical Characteristics (产品尺寸):**



**Product Package (产品包装):**

Inner Box (内盒)	Outer Carton (外箱)
	
<p>25pcs/layer 8layers/box Gross weight: 0.8kg/box Box dimension: 13*13*13cm</p>	<p>20boxes/carton 4,000pcs/carton Gross weight: 17kg/CTN Carton Dimension: 64*28*32cm</p>